

# *Gig*BAR LT

## User Manual

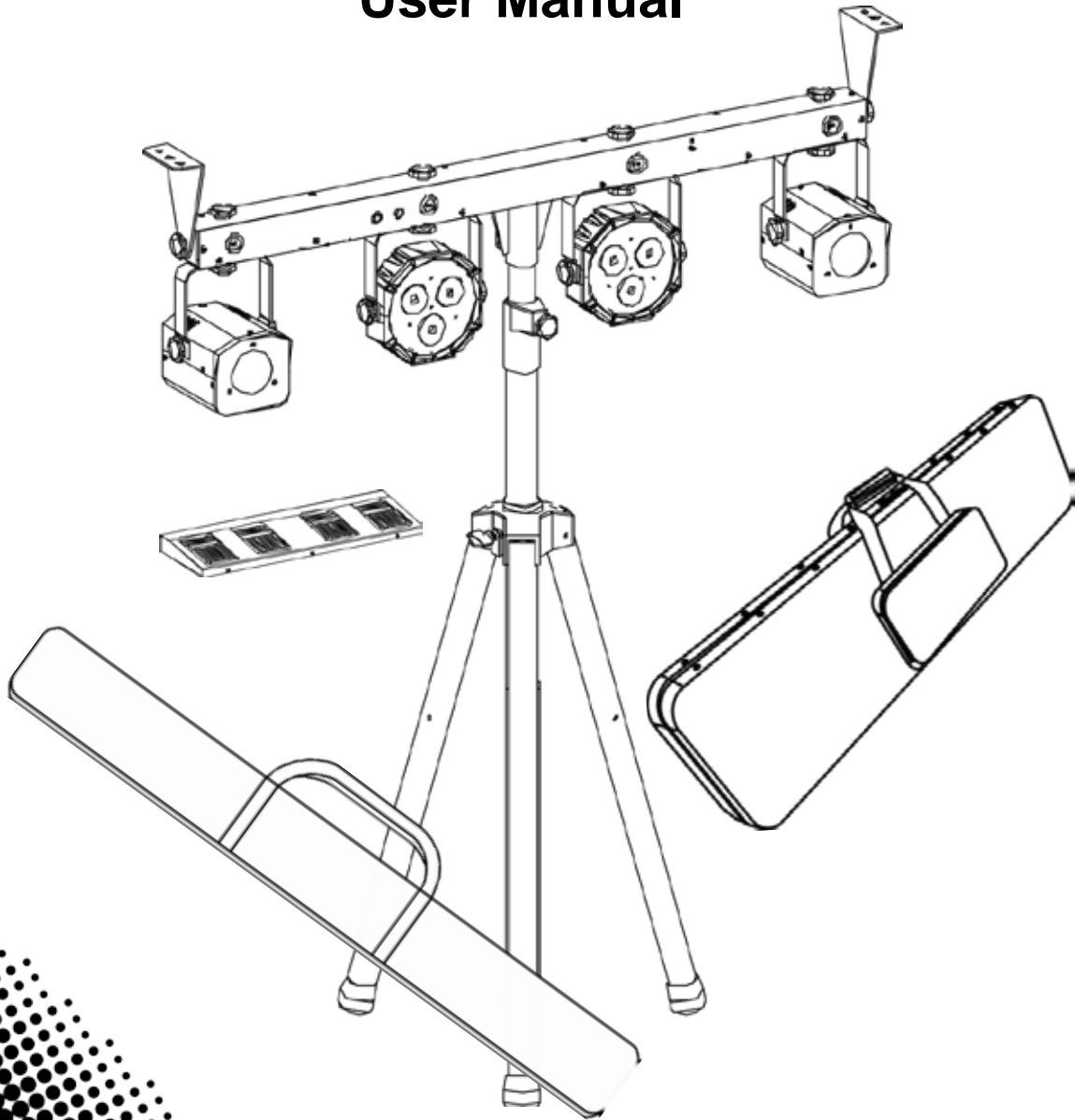

---

# TABLE OF CONTENTS

<b>1. Before You Begin</b> .....	<b>3</b>
What Is Included .....	3
Unpacking Instructions .....	3
Claims.....	3
Text Conventions .....	3
Symbols .....	3
Disclaimer .....	3
Product at a Glance .....	4
Safety Notes.....	4
<b>2. Introduction</b> .....	<b>5</b>
Product Overview .....	5
Product Dimensions .....	6
<b>3. Setup</b> .....	<b>7</b>
AC Power .....	7
Fuse Replacement .....	7
Power Linking .....	7
Mounting .....	8
Orientation .....	8
Rigging .....	8
<b>4. Operation</b> .....	<b>9</b>
Control Panel Operation.....	9
Menu Map .....	9
DMX Linking.....	10
Configuration (DMX) .....	10
DMX Personality and Starting Address.....	10
DMX Channel Assignments and Values .....	10
17CH .....	10
17CH (cont.) .....	11
06CH .....	12
03CH .....	12
Configuration (Standalone) .....	13
Auto Mixed Effects.....	13
Sound-Active Mixed Effects .....	13
Show Mode.....	13
Color Mixing.....	14
Rearranging the Fixtures .....	14
Factory Reset .....	14
Master/Slave Mode .....	14
Footswitch Operation .....	15
IRC-6 Infrared Remote Control .....	16
IRC-6 Operation.....	16
<b>5. Maintenance</b> .....	<b>17</b>
Product Maintenance .....	17
<b>6. Technical Specifications</b> .....	<b>18</b>
<b>Returns</b> .....	<b>20</b>
<b>Contact Us</b> .....	<b>21</b>

# 1. BEFORE YOU BEGIN

## What Is Included

- GigBAR LT
- Power Cord
- Carrying Cases
- Tripod
- Footswitch
- Warranty Card
- Quick Reference Guide
- IRC-6 Remote

## Unpacking Instructions

Carefully unpack the product immediately and check the container to make sure all the parts are in the package and are in good condition.

## Claims





If the box or the contents (the product and included accessories) appear damaged from shipping, or show signs of mishandling, notify the carrier immediately, not Chauvet. Failure to report damage to the carrier immediately may invalidate your claim. In addition, keep the box and contents for inspection.

For other issues, such as missing components or parts, damage not related to shipping, or concealed damage, file a claim with Chauvet within 7 days of delivery.

## Text Conventions

Convention	Meaning
1—512	A range of values
50/60	A set of values of which only one can be chosen
Settings	A menu option not to be modified
Menu > Settings	A sequence of menu options to be followed
<ENTER>	A key to be pressed on the product's control panel
ON	A value to be entered or selected

## Symbols

Symbol	Meaning
	Electrical warning. Not following these instructions may cause electrical damage to the product, accessories, or the user.
	Critical installation, configuration, or operation information. Not following these instructions may make the product not work, cause damage to the product, or cause harm to the operator.
	Important installation or configuration information. The product may not function correctly if this information is not used.
	Useful information.

## Disclaimer

Chauvet believes that the information contained in this manual is accurate in all respects. However, Chauvet assumes no responsibility and specifically disclaims any and all liability to any party for any loss, damage or disruption caused by any errors or omissions in this document, whether such errors or omissions result from negligence, accident or any other cause. Chauvet reserves the right to revise the content of this document without any obligation to notify any person or company of such revision, however, Chauvet has no obligation to make, and does not commit to make, any such revisions. Download the latest version from [www.chauvetlighting.com](http://www.chauvetlighting.com).

The works of authorship contained in this manual, including, but not limited to, all design, text and images are owned by Chauvet.

© Copyright 2016 Chauvet & Sons, LLC. All rights reserved.

Electronically published by Chauvet in the United States of America.

CHAUVET, the Chauvet logo, and GigBAR LT are registered trademarks or trademarks of Chauvet & Sons LLC (d/b/a Chauvet and Chauvet Lighting) in the United States and other countries. Other company and product names and logos referred to herein may be trademarks of their respective companies.

## Product at a Glance

Use on Dimmer	X	Auto Programs	P
Outdoor Use	X	Auto-ranging Power Supply	P
Sound-Active	P	Replaceable Fuse	P
DMX	P	User-Serviceable	X
Master/Slave	P		

## Safety Notes

Please read the following Safety Notes carefully before working with the product. The Notes include important safety information about installation, usage, and maintenance.



- Always connect the product to a grounded circuit to avoid the risk of electrocution.
- Always disconnect the product from the power source before cleaning or replacing the fuse.
- Avoid direct eye exposure to the light source while the product is on.
- Make sure the power cord is not crimped or damaged.
- Never disconnect the product from power cord by pulling or tugging on the cord.
- If mounting the product overhead, always secure to a fastening device using a safety cable.
- Make sure there are no flammable materials close to the product when operating.
- Do not touch the product's housing when operating because it may be very hot.



- The product is not intended for permanent installation.
- Always make sure that the voltage of the outlet to which you are connecting the product is within the range stated on the decal or rear panel of the product.
- The product is for indoor use only! (IP20) To prevent risk of fire or shock, do not expose the product to rain or moisture.
- Always install the product in a location with adequate ventilation, at least 20 in (50 cm) from adjacent surfaces.
- Be sure that no ventilation slots on the product's housing are blocked.
- Never connect the product to a dimmer.
- Make sure to replace the fuse with another of the same type and rating.
- Never carry the product from the power cord or any moving part. Always use the hanging/mounting bracket.
- The maximum ambient temperature (Ta) is 104 °F (40 °C). Do not operate the product at higher temperatures.
- In the event of a serious operating problem, stop using the product immediately.
- Never try to repair the product. Repairs carried out by unskilled people can lead to damage or malfunction. Please contact the nearest authorized technical assistance center.
- To eliminate unnecessary wear and improve its lifespan, during periods of non-use completely disconnect the product from power via breaker or by unplugging it.



Keep this User Manual for future use. If you sell the product to someone else, be sure that they also receive this document.

## 2. INTRODUCTION

### Product Overview

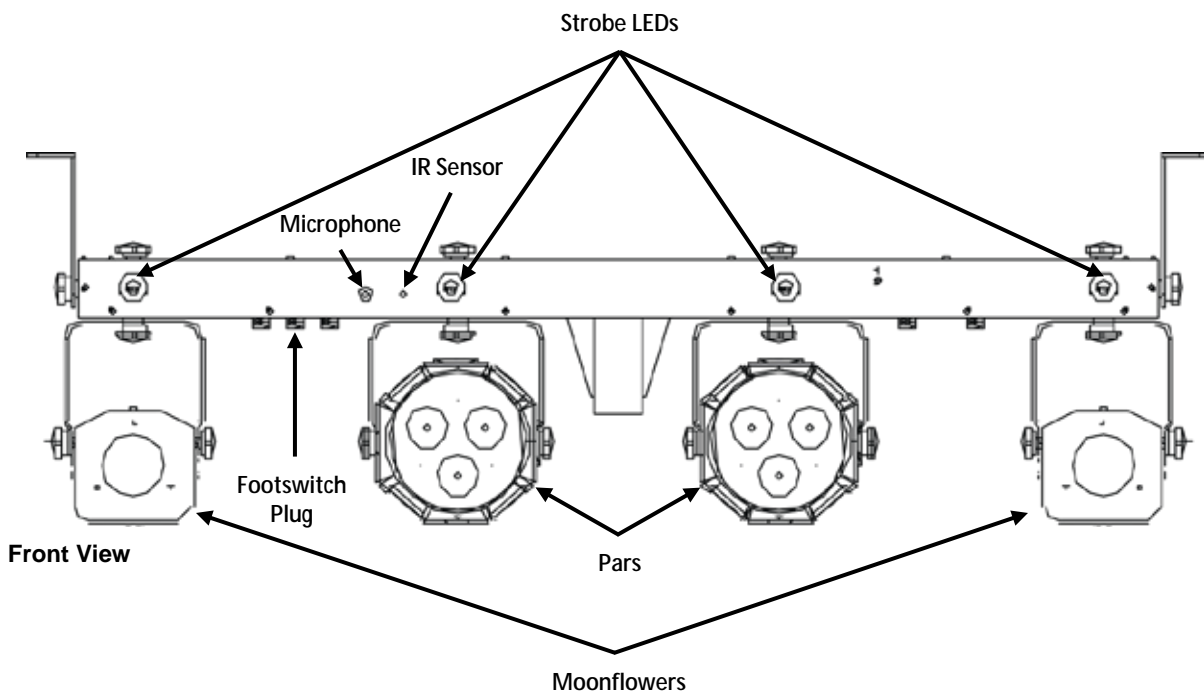
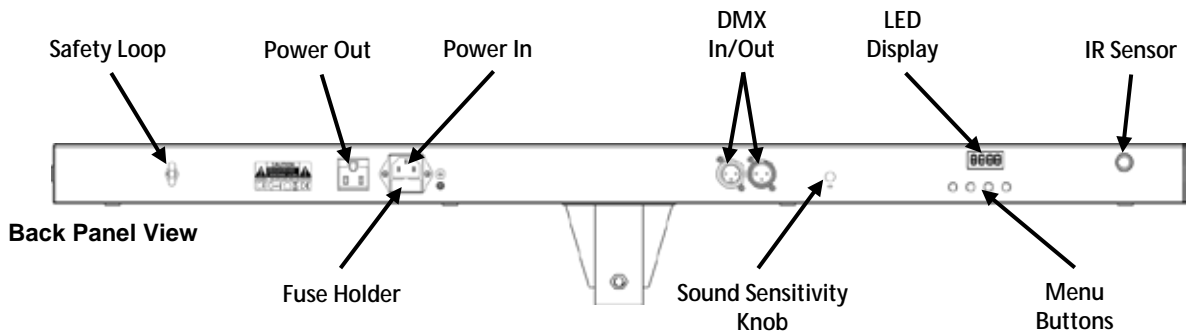

# Product Dimensions

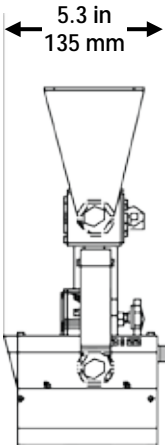
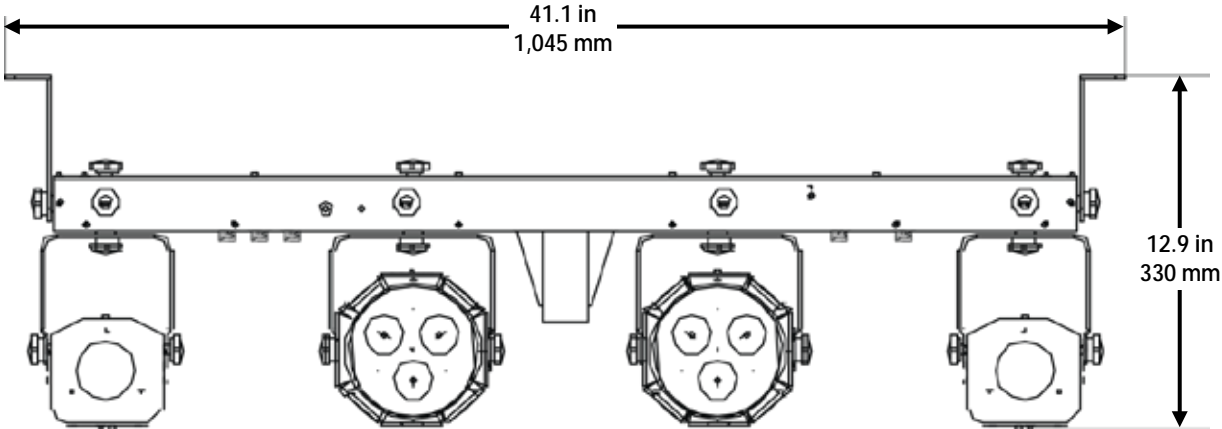

### 3. SETUP

#### AC Power

The GigBAR LT has an auto-ranging power supply and it can work with an input voltage range of 100 to 240 VAC, 50/60 Hz. To determine the product's power requirements (circuit breaker, power outlet, and wiring), use the current value listed on the label affixed to the product's back panel, or refer to the product's specifications chart. The listed current rating indicates the product's average current draw under normal conditions.



- **Always connect the product to a protected circuit (circuit breaker or fuse). Make sure the product has an appropriate electrical ground to avoid the risk of electrocution or fire.**
- **To eliminate unnecessary wear and improve its lifespan, during periods of non-use completely disconnect the product from power via breaker or by unplugging it.**



**Never connect the product to a rheostat (variable resistor) or dimmer circuit, even if the rheostat or dimmer channel serves only as a 0 to 100% switch.**

#### Fuse Replacement

1. Wedge the tip of a flat-head screwdriver into the slot of the fuse holder.
2. Pry the fuse holder out of the housing.
3. Remove the blown fuse from the holder and replace with a fuse of the exact same type and rating.
4. Insert the fuse holder back in place and reconnect power.

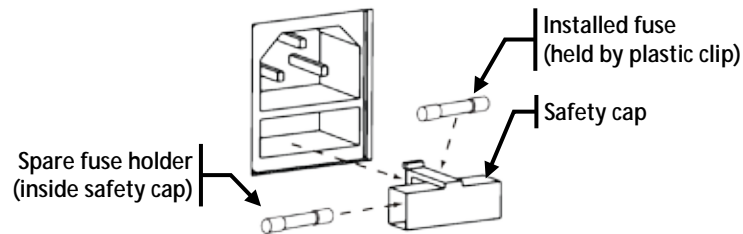

**Disconnect the product from the power outlet before replacing the fuse.**

#### Power Linking

The product provides power linking via the Edison outlet located in the back of the product. Please see the diagram below for further explanation.

#### Power Linking Diagram

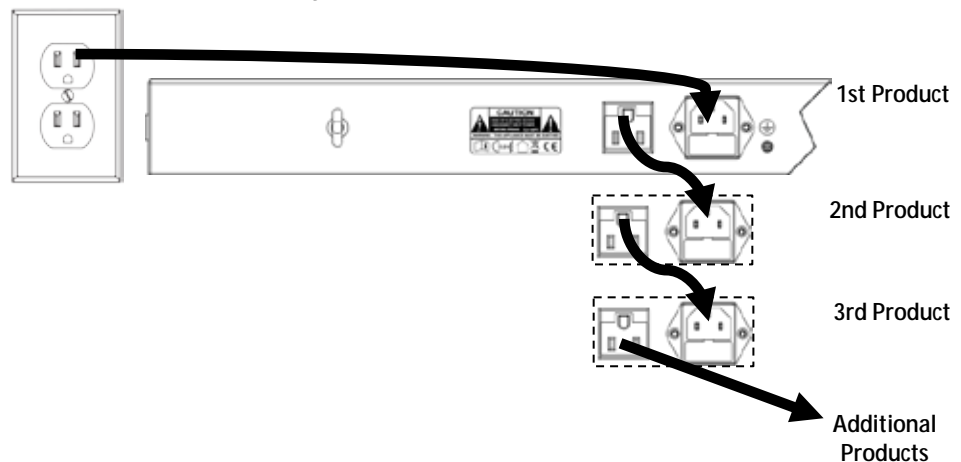

**You can power link up to 11 GigBAR LT products on 120 VAC or up to 20 GigBAR LT products on 230 VAC.**



**The power linking diagram corresponds to the North American version of the product ONLY! If using the product in other markets, you must consult with the local Chauvet distributor as power linking connectors and requirements may differ in your country or region.**

---

**Mounting** Before mounting the product, read and follow the safety recommendations indicated in the [Safety Notes](#).

**Orientation** The GigBAR LT may be mounted in any position; however, make sure adequate ventilation is provided around the product.

- Rigging**
- Before deciding on a location for the product, always make sure there is easy access to the product for maintenance and programming purposes.
  - Make sure that the structure onto which you are mounting the product can support the product's weight. See the [Technical Specifications](#) for weight information.
  - When mounting the product overhead, always use a safety cable. Mount the product securely to a rigging point, whether an elevated platform or a truss.
  - When rigging the product onto a truss, use a mounting clamp of appropriate weight capacity.
  - When power linking multiple products, mount the products close enough for power linking cables to reach.
  - The bracket adjustment knobs allow for directional adjustment when aiming the product to the desired angle. Only loosen or tighten the bracket knobs manually. Using tools could damage the knobs.

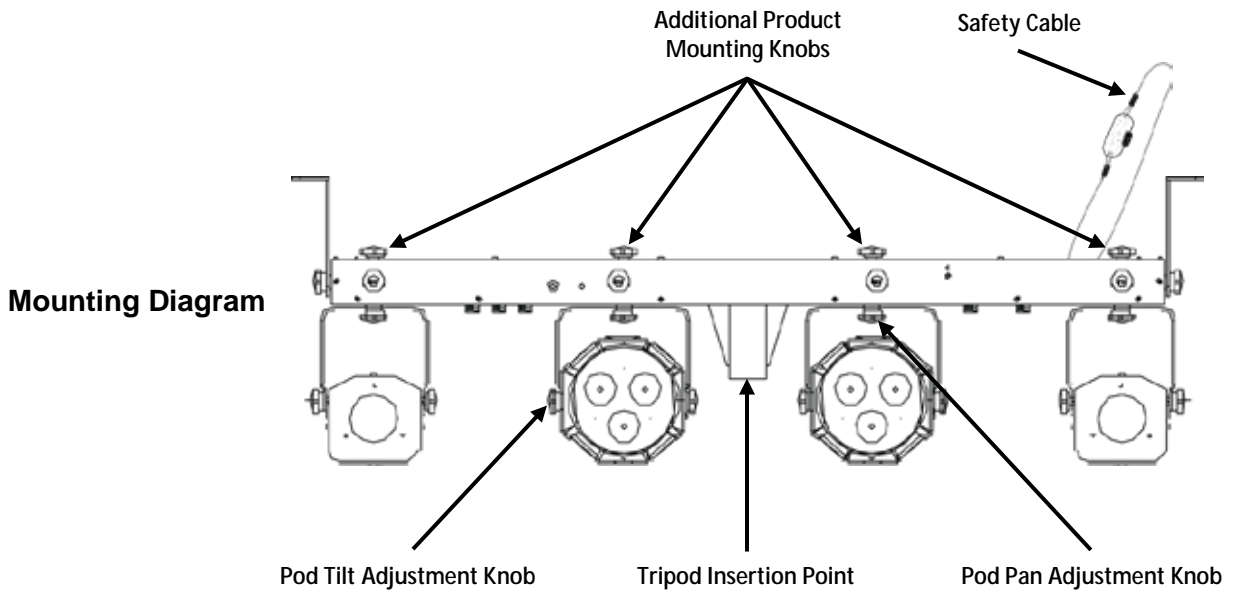



## 4. OPERATION

**Control Panel Operation** To access the control panel functions, use the four buttons located underneath the display. Please refer to the [Product Overview](#) to see the button locations on the control panel.

Button	Function
<MENU>	Press to find an operation mode or to back out of the current menu option
<UP>	Press to scroll up the list of options or to find a higher value
<DOWN>	Press to scroll down the list of options or to find a lower value
<ENTER>	Press to activate a menu option or a selected value

### Menu Map

Main Level	Programming Levels			Description	
Aut_	Aut1	F 01–F 99		Auto mixed effect 1 (speed)	
	Aut2			Auto mixed effect 2 (speed)	
Sud_	Sud1			Sound-Active mixed effect 1	
	Sud2			Sound-Active mixed effect 2	
ShoW	AP--	AP01–AP07	F 01–F 99	Auto Par programs (speed)	
	AM01		F 01–F 99	Auto Moonflower programs (speed)	
	AS--	AS01–AS10	F 01–F 99	Auto Strobe programs (speed)	
	APM-	APM1–APM4	F 01–F 99	Auto Par + Moonflower programs (speed)	
	APS1		F 01–F 99	Auto Par + Strobe programs (speed)	
	AMS1		F 01–F 99	Auto Moonflower + Strobe programs (speed)	
	SP--		SP01–SP07	Sound-Active par programs	
	SM01				Sound-Active Moonflower program
	SS--		SS01–SS10	Sound-Active Strobe programs	
	SPM-		SPM1–SPM4	Sound-Active Par + Moonflower programs	
	SPS1				Sound-Active Par + Strobe program
	SMS1				Sound-Active Moonflower + Strobe program
	CoLo	r000–r255	g000–g255	b000–b255	Custom mix colors (red, green, and blue)
d_ _ _	17CH		d001–d496	Sets 17-channel DMX personality and address	
	06CH		d001–d507	Sets 6-channel DMX personality and address	
	03CH		d001–d510	Sets 3-channel DMX personality and address	
SLAV	SLAV			Slave mode	
SYS	dSEt		1234	Rearrange fixtures (see <a href="#">Rearranging the Fixtures</a> for more information)	
	rSEt			Resets to factory defaults	

## DMX Linking

The GigBAR LT works with a DMX controller. Information about DMX is in the CHAUVET DMX Primer, which is available from the Chauvet website [http://www.chauvetlighting.com/downloads/DMX\\_Primer\\_rev05\\_WO.pdf](http://www.chauvetlighting.com/downloads/DMX_Primer_rev05_WO.pdf).

## Configuration (DMX)

Set the product in DMX mode to control with a DMX controller.

1. Connect the product to a suitable power outlet.
2. Connect a DMX cable from the DMX output of the DMX controller to the DMX input socket on the product.

## DMX Personality and Starting Address

When selecting a starting DMX address, always consider the number of DMX channels the selected DMX mode uses. If you choose a starting address that is too high, you could restrict the access to some of the product's channels.

The GigBAR LT uses up to 17 DMX channels in a 17-channel DMX mode, which defines the highest configurable address to **496**.

If you are not familiar with the DMX protocol, download the DMX Primer from [www.chauvetlighting.com](http://www.chauvetlighting.com).

To select the starting address, do the following:

1. Press **<MENU>** repeatedly until **d \_ \_ \_** shows on the display.
2. Press **<ENTER>**.
3. Use **<UP>** or **<DOWN>** to select **17CH**, **06CH**, or **03CH**.
4. Press **<ENTER>**, and **d 1-d496** (for **17CH**), **d 1-d507** (for **06CH**), or **d 1-d510** (for **03CH**) will show on the display.
5. Use **<UP>** or **<DOWN>** to select the starting address.
6. Press **<ENTER>**.

## DMX Channel Assignments and Values

17CH	Channel	Function	Value	Percent/Setting
	1	Par 1 Red	000ó 255	0–100%
	2	Par 1 Green	000ó 255	0–100%
	3	Par 1 Blue	000ó 255	0–100%
	4	Par 1 Shutter	000ó 127	Dimmer 0–100%
			128ó 239	Strobe, slow to fast
			240ó 249	Sound-activated strobe
			250ó 255	Full on
	5	Par 2 Red	000ó 255	0–100%
	6	Par 2 Green	000ó 255	0–100%
	7	Par 2 Blue	000ó 255	0–100%
	8	Par 2 Shutter	000ó 127	Dimmer 0–100%
			128ó 239	Strobe, slow to fast
			240ó 249	Sound-activated strobe
			250ó 255	Full on
	9	Moonflower 1 Color	000ó 024	No function
			025ó 049	Red
			050ó 074	Green
			075ó 099	Blue
			100ó 124	Red + green
			125ó 149	Red + blue
			150ó 174	Green + blue
			175ó 199	Red + green + blue
			200ó 224	Auto single color loop
			225ó 255	Auto two color loop

**17CH**  
(cont.)

Channel	Function	Value	Percent/Setting
10	<b>Moonflower 1 Strobe</b> (When CH9 is 025ó 199)	000ó 009	No function
		010ó 239	Strobe, slow to fast
		240ó 255	Sound-activated strobe
	<b>Moonflower 1 Auto Speed</b> (When CH9 is 200ó 255)	000ó 239	Auto speed, slow to fast
		240ó 255	Sound-activated mode
11	<b>Moonflower 1 Rotation</b>	000ó 004	Stop
		005ó 127	Rotate clockwise, slow to fast
		128ó 133	Stop
		134ó 255	Rotate counter-clockwise, slow to fast
12	<b>Moonflower 2 Color</b>	000ó 024	No function
		025ó 049	Red
		050ó 074	Green
		075ó 099	Blue
		100ó 124	Red + green
		125ó 149	Red + blue
		150ó 174	Green + blue
		175ó 199	Red + green + blue
		200ó 224	Auto single color loop
225ó 255	Auto two color loop		
13	<b>Moonflower 2 Strobe</b> (When CH12 is 025ó 199)	000ó 009	No function
		010ó 239	Strobe, slow to fast
		240ó 255	Sound-activated strobe
	<b>Moonflower 2 Auto Speed</b> (When CH12 is 200ó 255)	000ó 239	Auto speed, slow to fast
		240ó 255	Sound-activated mode
14	<b>Moonflower 2 Rotation</b>	000ó 004	Stop
		005ó 127	Rotate clockwise, slow to fast
		128ó 133	Stop
		134ó 255	Rotate counter-clockwise, slow to fast
15	<b>Strobe Program</b>	000ó 009	All on (CH16 must be active)
		010ó 029	Auto program 1
		030ó 049	Auto program 2
		050ó 069	Auto program 3
		070ó 089	Auto program 4
		090ó 109	Auto program 5
		110ó 129	Auto program 6
		130ó 149	Auto program 7
		150ó 169	Auto program 8
		170ó 189	Auto program 9
		190ó 209	All strobing
		210ó 255	Sound-activated strobe
16	<b>Strobe Dimmer</b>	000ó 255	0–100%
17	<b>Strobe Speed</b>	000ó 255	Strobe speed, slow to fast

<b>06CH</b>	<b>Channel</b>	<b>Function</b>	<b>Value</b>	<b>Percent/Setting</b>
	1	Red	000ó 255	0–100%
	2	Green	000ó 255	0–100%
	3	Blue	000ó 255	0–100%
	4	Shutter	000ó 127	Dimmer 0–100%
			128ó 239	Strobe, slow to fast
			240ó 249	Sound-activated strobe
			250ó 255	Full on
	5	Moonflower Rotation	000ó 004	Stop
			005ó 127	Rotate clockwise, slow to fast
			128ó 133	Stop
			134ó 255	Rotate counter-clockwise, slow to fast
	6	Strobe	000ó 054	Strobe dimmer 0–100%
			055ó 249	Strobe speed slow to fast

<b>03CH</b>	<b>Channel</b>	<b>Function</b>	<b>Value</b>	<b>Percent/Setting</b>
	1	Auto/Sound Programs	000ó 009	No function
			010ó 119	Auto mixed effect 1, slow to fast
			120ó 229	Auto mixed effect 2, slow to fast
			230ó 234	Sound-activated mixed effect 1
			235ó 239	Sound-activated mixed effect 2
			240ó 255	Show mode (CH2 must be active)
	2	Show Mode (CH1 must be 240ó 255)	000ó 009	No function
			010ó 029	Pars
			030ó 049	Moonflowers
			050ó 069	Strobes
			070ó 089	Pars + Moonflowers
			090ó 109	Pars + Strobes
			110ó 129	Moonflowers + Strobes
			130ó 149	Sound-Active Pars
			150ó 169	Sound-Active Moonflowers
			170ó 189	Sound-Active Strobes
			190ó 209	Sound-Active Pars + Moonflowers
			210ó 229	Sound-Active Pars + Strobes
	230ó 255	Sound-Active Moonflowers + Strobes		
	3	Show Mode Speed	000ó 255	CH2 program speed, slow to fast

---

## Configuration (Standalone)

Set the product in one of the standalone modes to control without a DMX controller.

- Connect the product to a suitable power outlet.



**Never connect a product that is operating in any standalone mode to a DMX string connected to a DMX controller. Products in standalone mode may transmit DMX signals that could interfere with the DMX signals from the controller.**

### Auto Mixed Effects

To run the GigBAR LT in one of the Auto mixed effects, follow the instructions below:

1. Press **<MENU>** repeatedly until **Aut\_** shows on the display.
2. Press **<ENTER>**.
3. Use **<UP>** or **<DOWN>** to select **Aut1** or **Aut2**.
4. Press **<ENTER>**. **F 01–F 99** will show on the display.
5. Use **<UP>** or **<DOWN>** to increase or decrease the program speed.

### Sound-Active Mixed Effects

To run the GigBAR LT in one of the Sound-Active mixed effects, do the following:

1. Press **<MENU>** repeatedly until **Sud\_** shows on the display.
2. Press **<ENTER>**.
3. Use **<UP>** or **<DOWN>** to select **Sud1** or **Sud2**.
4. Press **<ENTER>**.
5. Turn the Sound Sensitivity Knob up until the product responds to the beat of the music. See the [Product Overview](#) for more information.



**The product will only respond to low frequencies of music (bass and drums).**

### Show Mode

To run the product in Show Mode, follow the instructions below:

1. Press **<MENU>** repeatedly until **ShoW** shows on the display.
2. Press **<ENTER>**.
3. Use **<UP>** or **<DOWN>** to select:
  - **AP--** (Auto Pars)
  - **AM01** (Auto Moonflowers)
  - **AS--** (Auto Strobes)
  - **APM-** (Auto Pars and Moonflowers)
  - **APS1** (Auto Pars and Strobes)
  - **AMS1** (Auto Moonflowers and Strobes)
  - **SP--** (Sound-Active Pars)
  - **SM01** (Sound-Active Moonflowers)
  - **SS--** (Sound-Active Strobes)
  - **SPM-** (Sound-Active Pars and Moonflowers)
  - **SPS1** (Sound-Active Pars and Strobes)
  - or
  - **SMS1** (Sound-Active Moonflowers and Strobes)
4. Press **<ENTER>**.
5. For:
  - **AP--**, use **<UP>** or **<DOWN>** to select **AP01–AP07**.
  - **AS--**, use **<UP>** or **<DOWN>** to select **AS01–AS10**.
  - **APM-**, use **<UP>** or **<DOWN>** to select **APM1–APM4**.
  - **SP--**, use **<UP>** or **<DOWN>** to select **SP01–SP07**.
  - **SS--**, use **<UP>** or **<DOWN>** to select **SS01–SS10**.
  - or
  - **SPM-**, use **<UP>** or **<DOWN>** to select **SPM1–SPM4**.For **AM01**, **APS1**, or **AMS1**, **F 01–F 99** will show on the display. Use **<UP>** or **<DOWN>** to increase or decrease the program speed.
6. Press **<ENTER>**.
7. For **AP--**, **AS--**, or **APM-**, **F 01–F 99** will show on the display. Use **<UP>** or **<DOWN>** to increase or decrease the program speed.

---

## Color Mixing

To custom mix a color, do the following:

1. Press **<MENU>** repeatedly until **CoLo** shows on the display.
2. Press **<ENTER>** and one of the following will show on the display:
  - **r\_ \_ \_** (red)
  - **g\_ \_ \_** (green)
  - **b\_ \_ \_** (blue)
3. Press **<ENTER>** to cycle through the color settings.
4. When the desired color shows on the display, use **<UP>** or **<DOWN>** to increase or decrease the color value.
5. Repeat steps 3 and 4 until the product outputs as desired.



**After setting the blue color value, pressing <ENTER> will cause CoLo to show on the display. Press <ENTER> to cycle through the colors again.**

## Rearranging the Fixtures

To rearrange the location of each fixture on the GigBAR LT, follow the instructions below:

1. Press **<MENU>** repeatedly until **SYS** shows on the display.
2. Press **<ENTER>**.
3. Use **<UP>** or **<DOWN>** to select **dSEt**.
4. Press **<ENTER>**.
5. Press **<UP>** to select which fixture to rearrange.
6. Press **<DOWN>** to change the address.
7. Repeat steps 5-6 until all fixtures are addressed correctly.
8. Press **<ENTER>**.

## Factory Reset

To reset the product to factory defaults, do the following:

1. Press **<MENU>** repeatedly until **SYS** shows on the display.
2. Press **<ENTER>**.
3. Use **<UP>** or **<DOWN>** to select **rSEt**.
4. Press **<ENTER>**.

## Master/Slave Mode

The Master/Slave mode allows a single GigBAR LT product (the master) to control the actions of one or more GigBAR LT products (the slaves) without the need of a DMX controller. The master product will be set to operate in either Stand-Alone mode or with the IRC-6, while the slave products will be set to operate in Slave mode. Once set and connected, the slave products will operate in unison with the master product.

Configure the products as indicated below.

### Slave products:

1. Press **<MENU>** repeatedly until **SLAV** shows on the display.
2. Press **<ENTER>** to accept.

### Master product:

1. Set the master product in Stand-Alone mode or with the IRC-6.
2. Make the master product the first product in the DMX daisy chain.

- **Configure all the slave products before connecting the master to the daisy chain.**



- **Never connect a DMX controller to a DMX string configured for Master/Slave operation because the controller may interfere with the signals from the master.**
- **Do not connect more than 31 slaves to the master.**

## Footswitch Operation

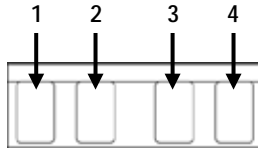

The included footswitch provides quick access to preset colors, color-change programs, and sound-activation through the GigBAR LT microphone.

### To use the Footswitch:

1. Connect the GigBAR LT to power.
2. Navigate to Auto or Sound mode.
3. Plug the footswitch cable into the Footswitch Plug on the product (see the [Product Overview](#)).
4. Press any pedal to activate footswitch control.

Pedal	Sub-option	Function
<b>1</b> <b>(Auto)</b>	1 <sup>st</sup> press	<b>Aut1</b> - Auto mixed effect 1
	2 <sup>nd</sup> press	<b>Aut2</b> - Auto mixed effect 2
	3 <sup>rd</sup> press	<b>Show</b> - Auto par effect 1
	4 <sup>th</sup> press	<b>Show</b> - Auto par effect 2
	5 <sup>th</sup> press	<b>Show</b> - Auto moonflower effect
	6 <sup>th</sup> press	<b>Show</b> - Auto par and moonflower effect 1
	7 <sup>th</sup> press	<b>Show</b> - Auto par and moonflower effect 2
	8 <sup>th</sup> press	<b>Show</b> - Auto par and moonflower effect 3
	9 <sup>th</sup> press	<b>Show</b> - Auto par and strobe effect
	10 <sup>th</sup> press	<b>Show</b> - Auto moonflower and strobe effect
<b>2</b> <b>(Sound)</b>	1 <sup>st</sup> press	<b>Sud1</b> - Sound-active mixed effect 1
	2 <sup>nd</sup> press	<b>Sud2</b> - Sound-active mixed effect 2
	3 <sup>rd</sup> press	<b>Show</b> - Sound-active par effect 1
	4 <sup>th</sup> press	<b>Show</b> - Sound-active par effect 2
	5 <sup>th</sup> press	<b>Show</b> - Sound-active moonflower effect
	6 <sup>th</sup> press	<b>Show</b> - Sound-active par and moonflower effect 1
	7 <sup>th</sup> press	<b>Show</b> - Sound-active par and moonflower effect 2
	8 <sup>th</sup> press	<b>Show</b> - Sound-active par and moonflower effect 3
	9 <sup>th</sup> press	<b>Show</b> - Sound-active par and strobe effect
	10 <sup>th</sup> press	<b>Show</b> - Sound-active moonflower and strobe effect
<b>3</b> <b>(Color)</b>	1 <sup>st</sup> press	Red
	2 <sup>nd</sup> press	Green
	3 <sup>rd</sup> press	Blue
	4 <sup>th</sup> press	Yellow (red and green)
	5 <sup>th</sup> press	Cyan (green and blue)
	6 <sup>th</sup> press	Purple (red and blue)
	7 <sup>th</sup> press	White (red, green, and blue)
<b>4</b> <b>(Blackout)</b>	N/A	Toggles Black Out (turns all lights off)

## IRC-6 Infrared Remote Control

The GigBAR LT is compatible with the IRC-6 infrared remote control from Chauvet. To activate IR mode, press any button on the IRC-6.

**Be sure the IRC-6 remote is pointing directly at the product and there is nothing in between the remote and the product.**

### IRC-6 Operation



#### Auto Mode

To run the product on an auto program:

1. Press **<AUTO>** on the IRC-6.
2. Press **<0>** – **<9>** to select an automatic program.
3. Use **<+>** or **<->** to increase or decrease the program speed.

#### Sound-Active Mode

To run the product on a Sound-Active program:

1. Press **<SOUND>** on the IRC-6.
2. Press **<0>** – **<9>** to select a Sound-Active program.

#### Strobe Modes

To run the strobes on a separate program from the other fixtures:

1. Set the mode for the rest of the product's fixtures
2. Press **<STROBE>** on the IRC-6.
3. Press **<0>** – **<9>** to select a strobe program.
4. Use **<+>** or **<->** to increase or decrease the program speed.

#### GigBAR LT IRC-6 Buttons:

Auto Mode / Sound-Active Mode	Strobe Modes
<b>&lt;0&gt;</b> - Mixed effect 1 (default)	<b>&lt;0&gt;</b> - Strobe all (default)
<b>&lt;1&gt;</b> - Mixed effect 2	<b>&lt;1&gt;</b> - Strobe Auto 1
<b>&lt;2&gt;</b> - Par 1	<b>&lt;2&gt;</b> - Strobe Auto 2
<b>&lt;3&gt;</b> - Par 2	<b>&lt;3&gt;</b> - Strobe Auto 3
<b>&lt;4&gt;</b> - Moonflower	<b>&lt;4&gt;</b> - Strobe Auto 4
<b>&lt;5&gt;</b> - Par + Moonflower 1	<b>&lt;5&gt;</b> - Strobe Auto 5
<b>&lt;6&gt;</b> - Par + Moonflower 2	<b>&lt;6&gt;</b> - Strobe Auto 6
<b>&lt;7&gt;</b> - Par + Moonflower 3	<b>&lt;7&gt;</b> - Strobe Auto 7
<b>&lt;8&gt;</b> - Par + Strobe	<b>&lt;8&gt;</b> - Strobe Auto 8
<b>&lt;9&gt;</b> - Moonflower + Strobe	<b>&lt;9&gt;</b> - Strobe Auto 9

#### Fade Mode

To set the Pars and Moonflowers to fade from color to color, press **<FADE>** on the IRC-6.

#### Manual Color Control

To manually select a color for the Pars and Moonflowers, press:

- **<R>** - for Red
  - **<G>** - for Green
  - **<B>** - for Blue
  - **<A>** - for Yellow (Red and Green)
  - **<UV>** - for Purple (Red and Blue)
- or
- **<W>** - for White (Red, Green, and Blue)

#### Black Out

To black out the light:

Press **<BLACK OUT>** on the IRC-6.

This will turn off the light until the button is pressed again.

**NOTE:** The IRC will not respond to any inputs when Black Out is activated. If the remote does not respond when a button is pressed, try pressing **<BLACK OUT>**. You may have inadvertently activated Black Out.



**All other buttons on the IRC-6 infrared remote control have no function with this product.**



---

## 5. MAINTENANCE

### **Product Maintenance**

Dust build-up reduces light output performance and can cause overheating. This can lead to reduction of the light source's life and/or mechanical wear. To maintain optimum performance and minimize wear, clean your lighting products at least twice a month. However, be aware that usage and environmental conditions could be contributing factors to increase the cleaning frequency.

To clean the product, follow the instructions below:

1. Unplug the product from power.
2. Wait until the product is at room temperature.
3. Use a vacuum (or dry compressed air) and a soft brush to remove dust collected on the external surface/vents.
4. Clean all transparent surfaces with a mild soap solution, ammonia-free glass cleaner, or isopropyl alcohol.
5. Apply the solution directly to a soft, lint free cotton cloth or a lens cleaning tissue.
6. Softly drag any dirt or grime to the outside of the transparent surface.
7. Gently polish the transparent surfaces until they are free of haze and lint.



**Always dry the transparent surfaces carefully after cleaning them.**

## 6. TECHNICAL SPECIFICATIONS

### Dimensions and Weight

GigBAR LT	Length	Width	Height	Weight
	41.1 in (1045 mm)	12.9 in (330 mm)	5.3 in (135 mm)	12 lb (5.5 kg)
Tripod	Max Height	Outer Pipe Diameter	Inner Pipe Diameter	Leg Width (Footprint)
	84 in (2134 mm)	1.5 in (38 mm)	1.4 in (35 mm)	40 in (1016 mm)

**Note:** Dimensions in inches rounded to the nearest decimal digit.

Power	Power Supply Type	Range	Voltage Selection
	Switching (internal)	100 to 240 VAC, 50/60 Hz	Auto-ranging
	Parameter	120 V, 60 Hz	230 V, 50 Hz
	Consumption	47 W	43 W
	Operating Current	0.7 A	0.4 A
	Power linking current (products)	8 A (11 products)	8 A (20 products)
	Fuse	F 1.6 A, 250 V	F 1.6 A, 250 V
	Power I/O	U.S./Worldwide	UK/Europe
	Power input connector	IEC	IEC
	Power output connector	Edison	IEC
	Power Cord plug	Edison (U.S.)	Local plug

### Light Source

Pars	Type	Power	Lifespan
	LED	2.6 W	50,000 hours
	Color	Quantity	Current
	Tri-color RGB	6	1.4 A
Moonflowers	Type	Power	Lifespan
	LED	5.4 W	50,000 hours
	Color	Quantity	Current
	Tri-color RGB	2	1.8 A
Strobes	Type	Power	Lifespan
	LED	1.2 W	50,000 hours
	Color	Quantity	Current
	White	4	356 mA

<b>Photometrics</b>	<b>Parameter</b>	<b>Value</b>
	Strobe Rate (Pars)	0 to 8.2 Hz
	Strobe Rate (Moonflowers)	0 to 8.2 Hz
	Strobe Rate (Strobes)	0 to 13.2 Hz
	Beam Angle (Pars)	13°
	Field Angle (Pars)	27°
	Illuminance @ 2 m (Pars)	1,609 lux (per pod)

<b>Thermal</b>	<b>Maximum External Temp.</b>	<b>Cooling System</b>
	104 °F (40 °C)	Convection

<b>DMX</b>	<b>I/O Connectors</b>	<b>Channel Range</b>
	3-pin XLR	3, 6 or 17

<b>Ordering</b>	<b>Product Name</b>	<b>Item Code</b>	<b>UPC Number</b>
	GigBAR LT	10031089	781462214388



---

# RETURNS

In case you need to get support or return a product:

- If you are located in the U.S., contact Chauvet World Headquarters.
- If you are located in the UK or Ireland, contact Chauvet Europe Ltd.
- If you are located in Mexico, contact Chauvet Mexico.
- If you are located in Benelux, contact Chauvet Europe BVBA.
- If you are located in any other country, DO NOT contact Chauvet. Instead, contact your local distributor. See [www.chauvetlighting.com](http://www.chauvetlighting.com) for distributors outside the U.S., UK, Ireland, Mexico, or Benelux.



**If you are located outside the U.S., UK, Ireland, Mexico, or Benelux, contact your distributor of record and follow their instructions on how to return Chauvet products to them. Visit our website [www.chauvetlighting.com](http://www.chauvetlighting.com) for contact details.**

Call the corresponding Chauvet Technical Support office and request a Return Merchandise Authorization (RMA) number before shipping the product. Be prepared to provide the model number, serial number, and a brief description of the cause for the return.

Send the merchandise prepaid, in its original box, and with its original packing and accessories. Chauvet will not issue call tags.

Clearly label the package with the RMA number. Chauvet will refuse any product returned without an RMA number.



**Write the RMA number on a properly affixed label. DO NOT write the RMA number directly on the box.**

Before sending the product, clearly write the following information on a piece of paper and place it inside the box:

- Your name
- Your address
- Your phone number
- RMA number
- A brief description of the problem

Be sure to pack the product properly. Any shipping damage resulting from inadequate packaging will be your responsibility. FedEx packing or double-boxing are recommended.



**Chauvet reserves the right to use its own discretion to repair or replace returned product(s).**

---

# CONTACT Us

## USA WORLD HEADQUARTERS

### General Information – Chauvet

Address: 5200 NW 108th Avenue  
Sunrise, FL 33351

Voice: (954) 577-4455

Fax: (954) 929-5560

Toll free: (800) 762-1084

### Technical Support

Voice: (954) 577-4455 (Press 4)

Fax: (954) 756-8015

Email: [tech@chauvetlighting.com](mailto:tech@chauvetlighting.com)

### World Wide Web

[www.chauvetlighting.com](http://www.chauvetlighting.com)

## EUROPE

### General Information - Chauvet Europe BVBA

Address: Stokstraat 18  
9770 Kruishoutem  
Belgium

Voice: +32 9 388 93 97

### Technical Support

Email: [Eutech@chauvetlighting.eu](mailto:Eutech@chauvetlighting.eu)

### World Wide Web

[www.chauvetlighting.eu](http://www.chauvetlighting.eu)

### General Information - Chauvet Europe Ltd.

Address: Unit 1C  
Brookhill Road Industrial Estate  
Pinxton, Nottingham, UK  
NG16 6NT

Voice: +44 (0)1773 511115

Fax: +44 (0)1773 511110

### Technical Support

Email: [uktech@chauvetlighting.com](mailto:uktech@chauvetlighting.com)

### World Wide Web

[www.chauvetlighting.co.uk](http://www.chauvetlighting.co.uk)

## MEXICO

### General Information - Chauvet Mexico

Address: Av. Santa Ana 30  
Parque Industrial Lerma  
Lerma, Mexico C.P. 52000

Voice: +52 (728) 285-5000

### Technical Support

Email: [servicio@chauvet.com.mx](mailto:servicio@chauvet.com.mx)

### World Wide Web

[www.chauvet.com.mx](http://www.chauvet.com.mx)

Outside the U.S., United Kingdom, Ireland, Mexico, or Benelux contact the dealer of record. Follow their instructions to request support or to return a product. Visit our website for contact details.