



User Manual

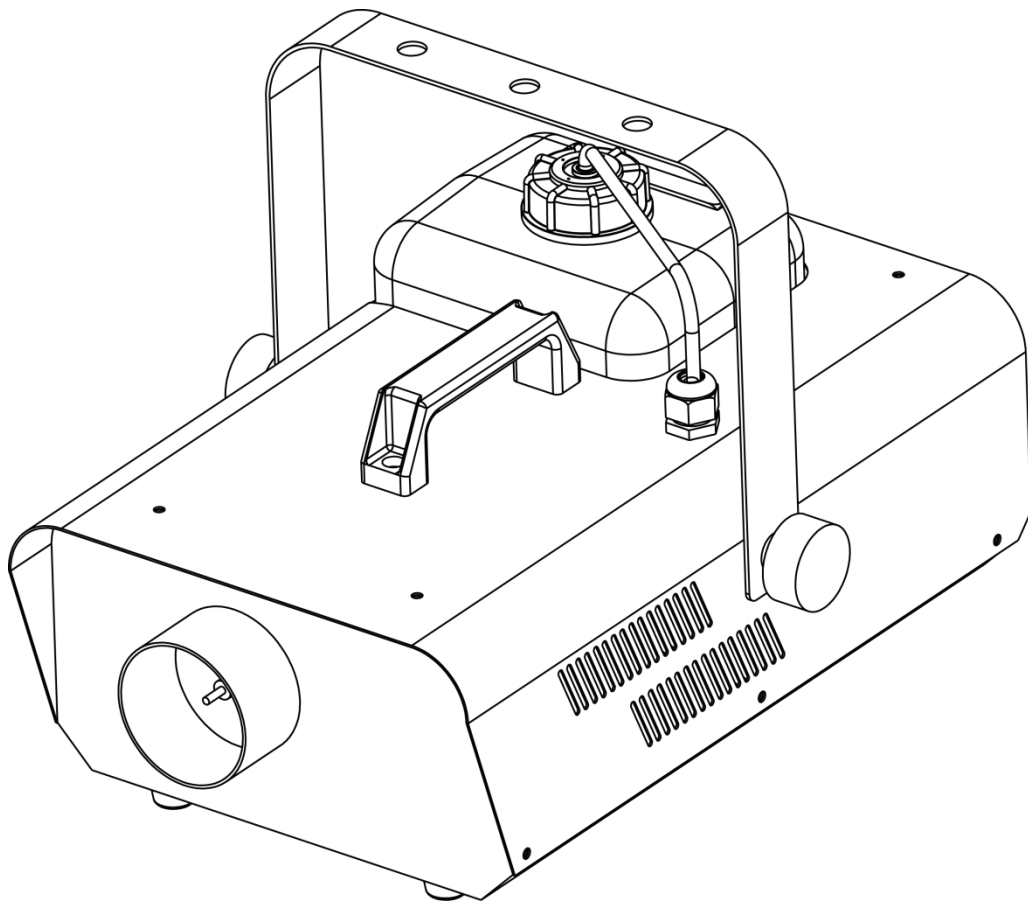

TABLE OF CONTENTS

1. BEFORE YOU BEGIN	3
What is Included.....	3
Unpacking Instructions.....	3
Product at a Glance.....	3
Safety Instructions.....	4
2. INTRODUCTION	5
Product Overview	5
Product Dimensions	6
3. SETUP	7
AC Power	7
Fuse Replacement	7
Mounting	8
Orientation	8
Rigging.....	8
4. OPERATING INSTRUCTIONS	9
Manual Remote Operation (FC-M) (Optional)	9
Timer Remote Operation (FC-T) (Standard)	9
Wireless Controller (FC-W) (Optional).....	10
General Troubleshooting.....	11
Contact Us	11
5. TECHNICAL INFORMATION	12
General Maintenance	12
Storage.....	12
Returns Procedure	13
TECHNICAL SPECIFICATIONS	14

1. BEFORE YOU BEGIN

What is Included

- Ø 1 x Hurricane™ 1300
- Ø Power Cord
- Ø 1 x FC-T wired timer remote
- Ø 1 x Warranty Card
- Ø 1 x Quick Reference Guide

Unpacking Instructions

Immediately upon receiving a fixture, carefully unpack the carton, check the contents to ensure that all parts are present, and have been received in good condition. Notify the shipper immediately and retain packing material for inspection if any parts appear damaged from shipping or the carton itself shows signs of mishandling. Save the carton and all packing materials. In the event that a fixture must be returned to the factory, it is important that the fixture be returned in the original factory box and packing.

Claims

The carrier is responsible for any damage incurred during shipping to this product or any part that shipped with it. Therefore, if the received merchandise appears to have damages caused during shipping, the customer must submit the damage report and any related claims with the carrier, not CHAUVET®. The customer must submit the report upon reception of the damaged merchandise. Failure to do so in a timely manner may invalidate the customer's claim with the carrier.

For other issues such as missing components or parts, damage not related to shipping, or concealed damage, the customer must make claims to CHAUVET® within seven (7) days of receiving the merchandise.

Product at a Glance

Use on Dimmer	×	Auto Programs	×
Outdoor Use	×	Auto-ranging Power Supply	×
Sound-Active	×	Replaceable Fuse	P
DMX	×	User-Serviceable	×
Master/Slave	×	Duty Cycle	×

Safety Instructions



Please read the following notes carefully because they include important safety information about the installation, usage, and maintenance of this product.

- Please keep this User Guide for future consultation. If you sell the unit to another user, be sure that they also receive this instruction booklet.
- Always make sure that you are connecting to the proper voltage, and that the line voltage you are connecting to is not higher than that stated on the decal or rear panel of the fixture.
- This product is intended for indoor use only! (If applicable)
- To prevent risk of fire or shock, do not expose fixture to rain or moisture. Make sure there are no flammable materials close to the unit while operating.
- The unit must be installed in a location with adequate ventilation, at least 20 in (50 cm) from adjacent surfaces. Be sure that no ventilation slots are blocked.
- Always disconnect from power source before servicing or replacing lamp or fuse and be sure to replace with same lamp source.
- Secure fixture to fastening device using a safety chain. Never carry the fixture solely by its head. Use its carrying handles.
- Maximum ambient temperature (Ta) is 104 °F (40 °C). Do not operate fixture at temperatures higher than this.
- In the event of a serious operating problem, stop using the unit immediately. Never try to repair the unit by yourself. Repairs carried out by unskilled people can lead to damage or malfunction. Please contact the nearest authorized technical assistance center. Always use the same type spare parts.
- Never connect the device to a dimmer pack.
- Make sure the power cord is never crimped or damaged.
- Never disconnect the power cord by pulling or tugging on the cord.
- Avoid direct eye exposure to the light source while it is on.



There are no user serviceable parts inside the unit. Do not open the housing or attempt any repairs yourself. In the unlikely event your unit may require service, please contact CHAUVET at: 954-577-4455.



FCQ (Fog Cleaner Quart) was specifically developed by Chauvet to clean your Hurricane™ 1300. Make sure you use FCQ regularly to increase the life of your fogger.

2. INTRODUCTION

Product Overview

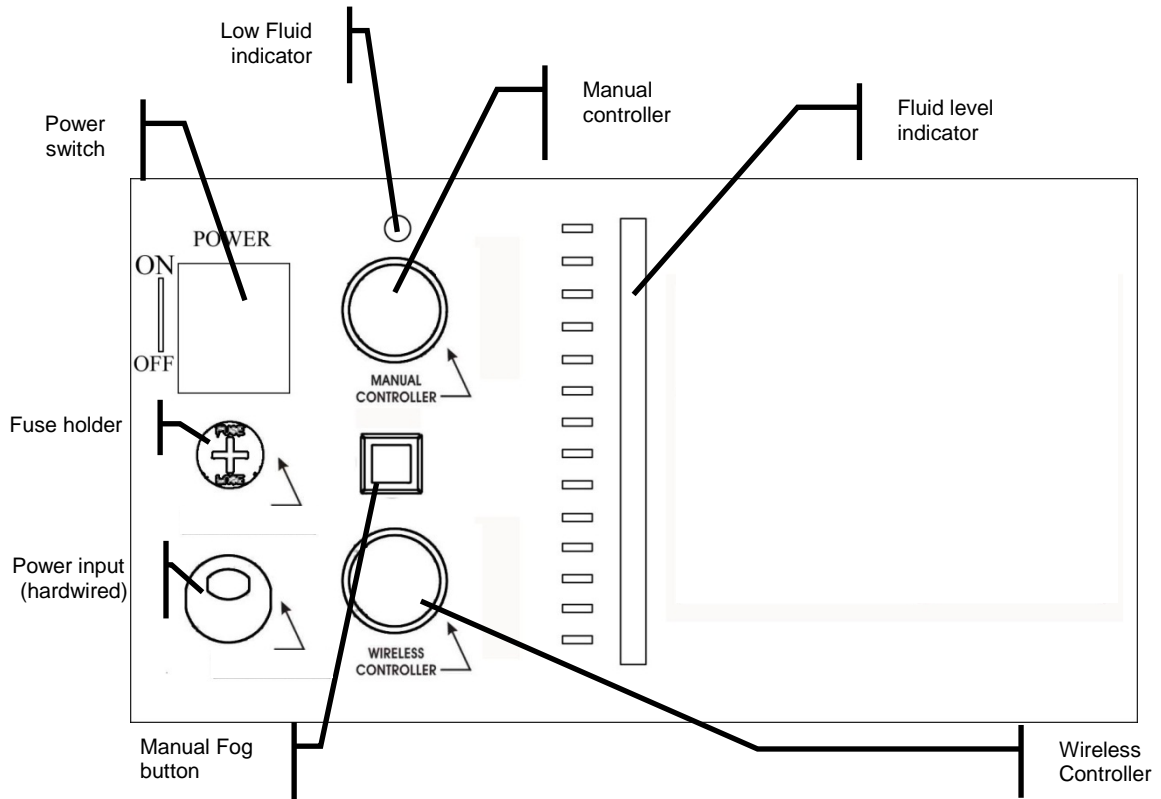
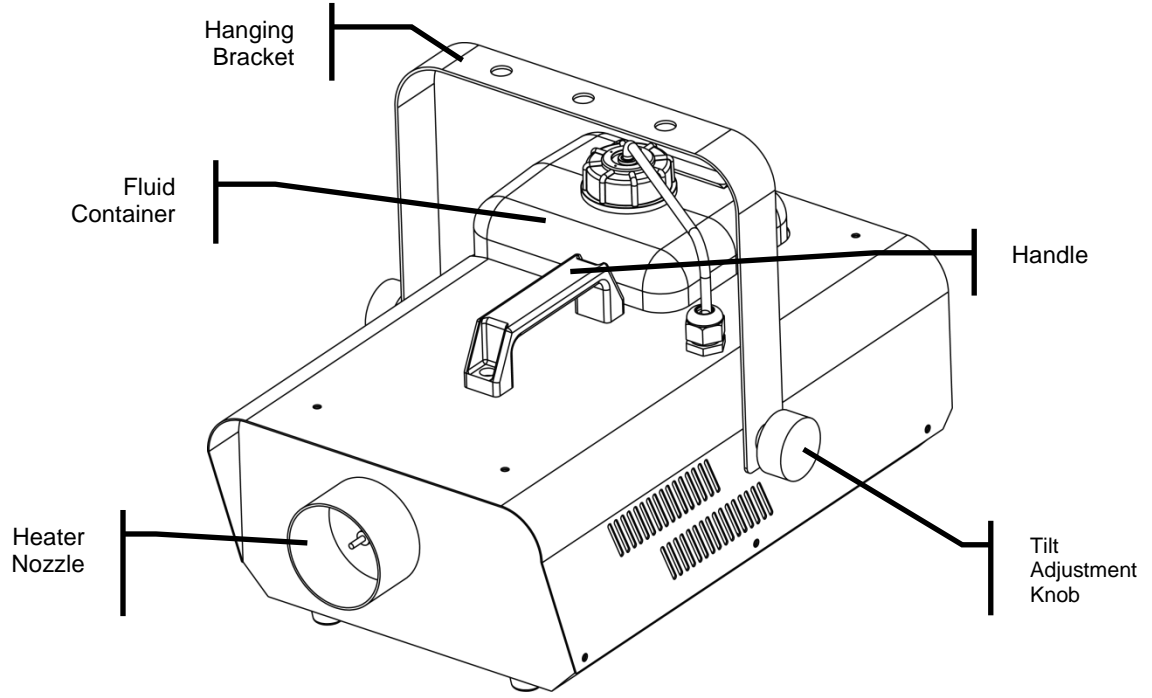

Product Dimensions

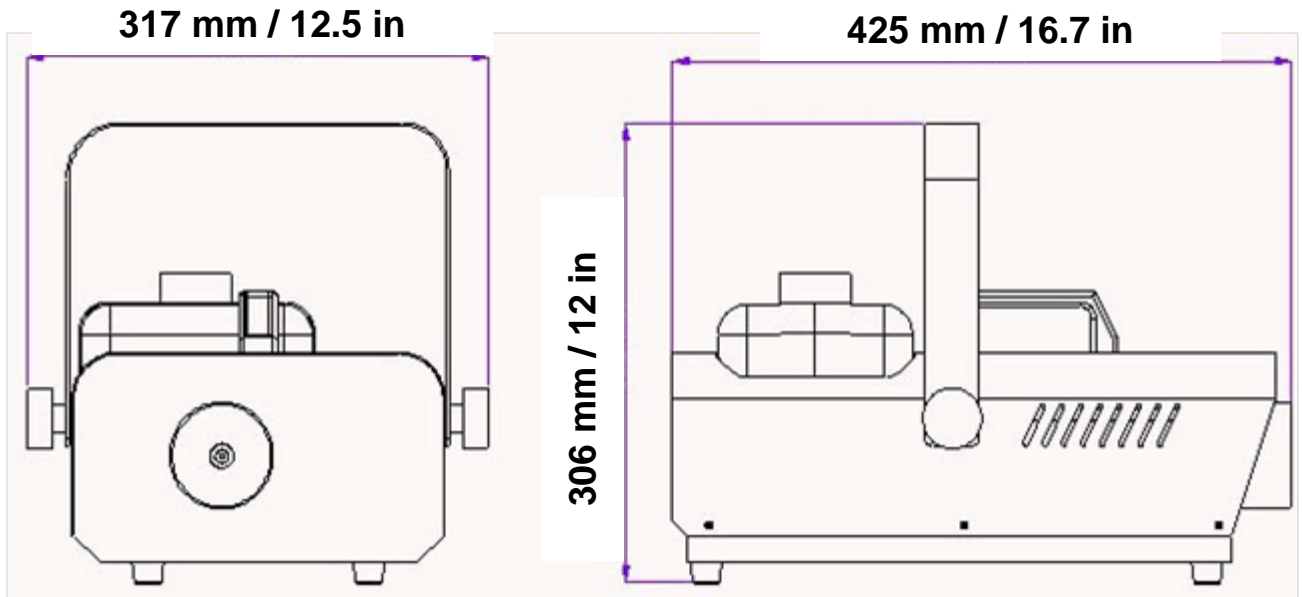

3. SETUP

AC Power

To determine the power requirements for a particular fixture, see the label affixed to the back plate of the fixture or refer to the fixture's specifications chart. A fixture's listed current rating is its average current draw under normal conditions. All fixtures must be powered directly off a switched circuit and cannot be run off a rheostat (variable resistor) or dimmer circuit, even if the rheostat or dimmer channel is used solely for a 0% to 100% switch. Before applying power to a fixture, check that the source voltage matches the fixture's requirement. Check the fixture or device carefully to make sure that if a voltage selection switch exists that it is set to the correct line voltage you will use.

Fuse Replacement



Unplug the IEC power cable before replacing the fuse! Always replace with same type of fuse.

This product has a replaceable fuse. In the event that the fuse needs to be replaced, follow the instructions provided below.

1. Using a flat head screwdriver, remove the fuseholder from the IEC housing.
2. Remove the bad fuse from the fuseholder.
3. Insert the new fuse into the fuseholder.
4. Install the fuseholder in the IEC housing.

The fuse is located inside this compartment. Remove using a flat head screwdriver.

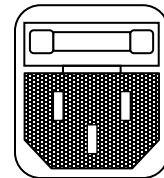

Mounting

Orientation

This fixture should only be mounted/used on a flat surface. This fixture may not be tilted.

Rigging

It is important never to obstruct the vents pathways. Mount the fixture using, a suitable “C” or “O” type clamp.

- When selecting installation location, take into consideration the fluid reservoir access and routine maintenance.
- Safety cables must always be used, utilizing the provided safety eye bolt or hanging bracket.
- Never mount in places where the fixture will be exposed to rain, high humidity, extreme temperature changes or restricted ventilation.

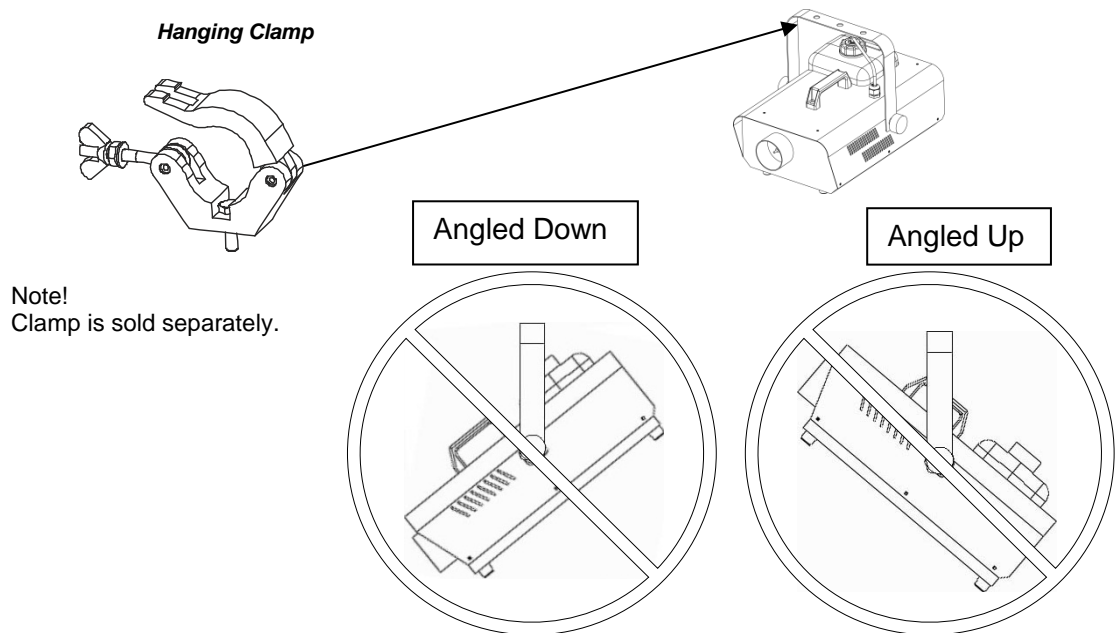

4. OPERATING INSTRUCTIONS

Manual Remote Operation (FC-M) (Optional)

1. Plug in the fog machine to power and turn the power switch to the fixture on.
2. Plug in the wired manual remote to the Manual Controller socket on the rear of the fog machine.
3. Press the single button located on the remote to trigger the fog output.



The button is momentary, which means that the fog machine will only output while the button is pressed. Once the button is released, the fog will stop outputting.

Timer Remote Operation (FC-T) (Standard)

This mode will allow you to control the fogger manually, set the fog machine to run continuously, or to set the fog machine to run off bursts with adjustable interval and duration settings.

1. Plug in the fog machine to power and turn the power switch to the fixture on.
2. Plug in the timer remote to the Manual Controller socket on the rear of the fog machine.
3. Press the TIMER ON/OFF button on the timer remote. The LED above the button should light, indicating activation of function.
4. You may now set the INTERVAL & DURATION adjustment knobs to the desired position.



The INTERVAL is the time between bursts of fog.

The DURATION is the time the fog machine will run during the burst.

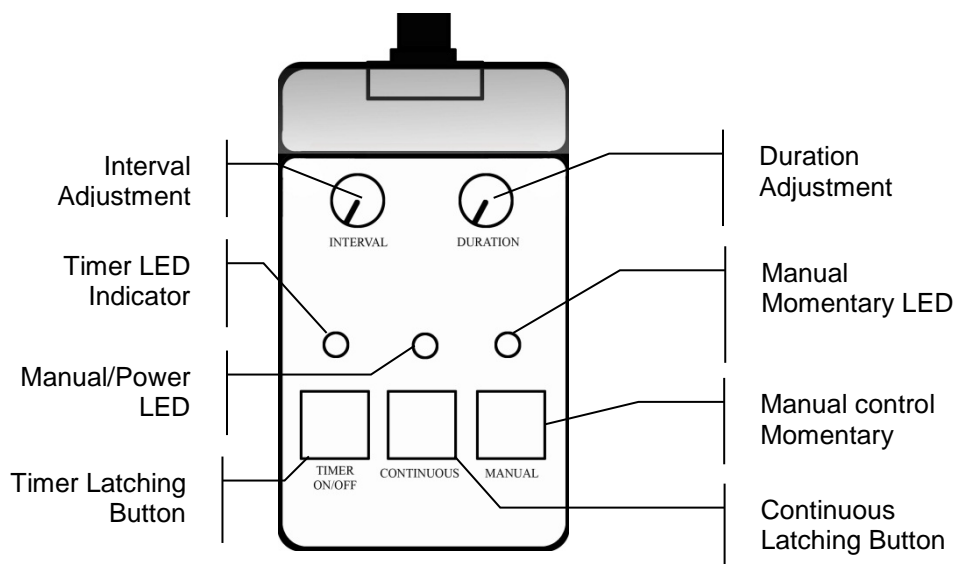

Wireless Controller (FC-W) (Optional)

This mode will allow you to control the fogger using the optional wireless controller. This consists of the transmitter and the receiver. You may control up to 4 independent fog machines or many more if you run them simultaneously. See the below instructions on setting up your fogger to operate with the FC-W.

1. Plug the wires receiver into the fog machine 5-pin port labeled "Wireless Controller".
2. There are 4 buttons on the wireless remote transmitter which act as triggers. Each button can be assigned to a different fog machine. You may only choose 1 dipswitch on each receiver. See the below configuration for setting the receivers to operate with the transmitter remote.

Mode	Dipswitches
CH1	1 = On, 2-4 = Off
CH2	2 = On, 1,3,4 = Off
CH3	3 = On, 1,2,4 = Off
CH4	4 = On, 1,2,3 = Off

3. Press the fog button, and the fog machine will output fog momentarily for as long as you hold down the button.

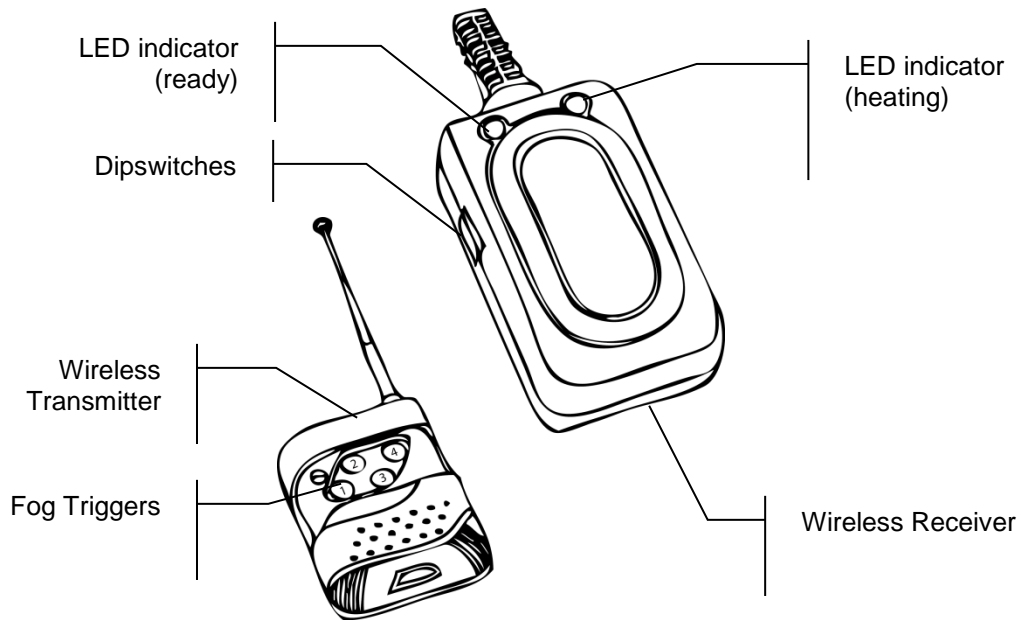

General Troubleshooting

Symptom	Solution(s)
No Power	Check mains power. Check external fuse. Check internal fuse.
No fog output	Check fluid level. Check remote. If using wireless, check batteries. If using wireless, check dipperswitches on receiver.
Breaker/Fuse keeps blowing	Possible electrical short. Contact Chauvet or a Chauvet Dealer/distributor for further instruction.
Low fog output	Run a cleaning solution through the fog machine. Check that the fog machine is plugged into the correct voltage.
Fog machine is not heating up	Check to replace the external fuse. Check to replace the internal fuse. Possible bad part. Contact Chauvet or a Chauvet Dealer/distributor for further instruction.
Remote does not work	Make sure connector is firmly connected to device. Try using another controller. Possible bad controller. Check the internal fuse. Check the external fuse.
Fluid indicator states no fog, but the container is full.	Try resetting the fog machine by turning the power off, and then on again. Possible bad part. Contact Chauvet or a Chauvet Dealer/distributor for further instruction.

If you still have a problem after trying the above solutions, please contact CHAUVET Technical Support at the location listed below.

Contact Us WORLD HEADQUARTERS - CHAUVET®

General Information

Address: 5200 NW 108th Avenue
Sunrise, FL 33351
Voice: (954) 577-4455
Fax: (954) 929-5560
Toll free: (800) 762-1084

Technical Support

Voice: (954) 577-4455 (Press 4)
Fax: (954) 756-8015
Email: tech@chauvetlighting.com

World Wide Web

www.chauvetlighting.com

UNITED KINGDOM AND IRELAND - CHAUVET® Europe Ltd.

General Information

Address: Unit 1C
Brookhill Road Industrial Estate
Pinxton, Nottingham, UK
NG16 6NT
Voice: +44 (0)1773 511115
Fax: +44 (0)1773 511110

Technical Support

Email: uktech@chauvetlighting.com

World Wide Web

www.chauvetlighting.co.uk

MEXICO - CHAUVET® Mexico

General Information

Address: Av. Santa Ana 30
Parque Industrial Lerma
Lerma, Mexico C.P. 52000
Voice: +52 (728) 285-5000

Technical Support

Email: servicio@chauvet.com.mx

World Wide Web

www.chauvet.com.mx

Outside the U.S., United Kingdom, Ireland, or Mexico, contact your dealer. Follow their instructions to request support or to return a product. Visit our website for contact details.

5. TECHNICAL INFORMATION

General Maintenance

Do not allow the fogger to become clogged. After every 40 hours of continuous operation, use CHAUVET® Fog Cleaner Quart (FCQ) through the system to prevent the accumulation of particulate matter in the heating element.

The recommended cleaning procedure is as follows.

1. Unplug the product from power.
2. Empty all fog fluid from the machine.
3. Add cleaning solution to the tank.
4. Connect the product to power and allow it to warm up.
5. Run the unit in a well-ventilated area until the tank is almost empty. **Do not allow the pump to run dry.**
6. Refill with fogger fluid to continue using the fogger. Run the machine briefly to clear any remaining cleaning solution from the pump and heater.



Fog Cleaner Quart (FCQ) was specifically developed by Chauvet® to clean your Hurricane™ 1300. Make sure you use FCQ regularly to increase the life of your product.

Storage

Before storing the fogger, run FCQ through the system as described in the cleaning procedure above; however, only follow steps 1 through 5. Do not refill the tank with fog fluid if storing the fogger. Cleaning the system prior to storage will help prevent any particles from condensing inside the pump or heater while not in use.



Test-run your Hurricane™ 1300 on a monthly basis to achieve the best performance.

Returns Procedure

Returned merchandise must be sent prepaid and in the original packing, call tags will not be issued. Package must be clearly labeled with a Return Merchandise Authorization Number (RMA #). Products returned without a RMA # will be refused. Call CHAUVET and request a RMA # prior to shipping the fixture. Be prepared to provide the model number, serial number and a brief description of the cause for the return. Be sure to properly pack fixture, any shipping damage resulting from inadequate packaging is the customer's responsibility. CHAUVET reserves the right to use its own discretion to repair or replace product(s). As a suggestion, proper UPS packing or double-boxing is always a safe method to use.

If you are given a RMA #, please include the following information on a piece of paper inside the box:

1. Your name
2. Your address
3. Your phone number
4. RMA #
5. A brief description of the symptoms

TECHNICAL SPECIFICATIONS

WEIGHT & DIMENSIONS

Length	16.7 in (425 mm)
Width	12.5 in (317 mm)
Height	12.0 in (306 mm)
Weight	16.8 lb (7.6 kg)

POWER

AC Power	120 VAC 60 Hz or 230 VAC 50 Hz
Fuse	13 A, 250 V
Power Consumption	1,328 W (11.2 A) max at 120 V
Inrush Power	(11.2 A) at 120 V
Power Factor	0.99 at 120 V
Fuse	7 A 250 V
Power Consumption	1,300 W (5.7 A) max at 230 V
Inrush Power	(1.83 A) at 230 V
Power Factor	0.99 at 230V

THERMAL

Maximum ambient temperature	104 °F (40 °C)
-----------------------------------	----------------

CONTROL & PROGRAMMING

Data input	5-pin & ground DIN5 female socket
Data pin configuration	pin1(LED), pin2(control), pin3(+5V), pin4(ground), pin5(none), ground(none)

ORDERING INFORMATION

Hurricane™ 1300	F1300
Wired manual remote (optional)	FC-M
Wired timer remote (included)	FC-T
Wireless manual remote (optional)	FC-W

SPARE PARTS ORDERING INFORMATION

Master PCB	P170-F3MSPCB
Heater	1P20-HT13
Pump	P200-F3PUMP
Fluid container	P170-F3FLC
Fluid sensor	P170-F1FLOS
Thermal switch	P170-THEF11
Bracket knob	P111-F3BKNOB
Fuse holder	P170-FUSEHOL
Manual fog button	P111-F3FOGB

WARRANTY INFORMATION

Warranty	1-year limited warranty
----------------	-------------------------