

Cumulus

User Manual

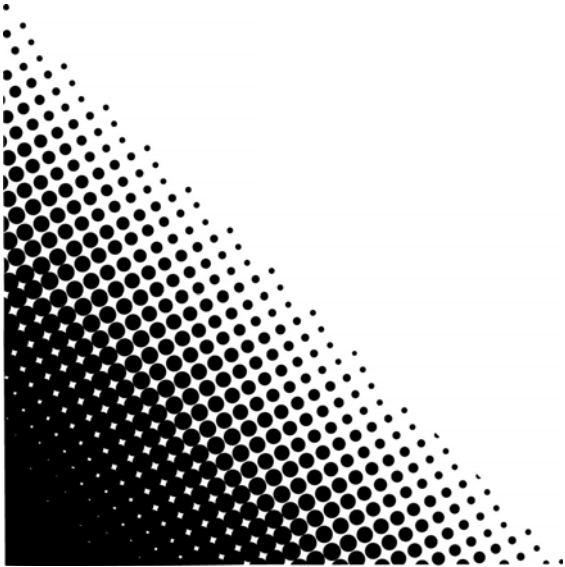
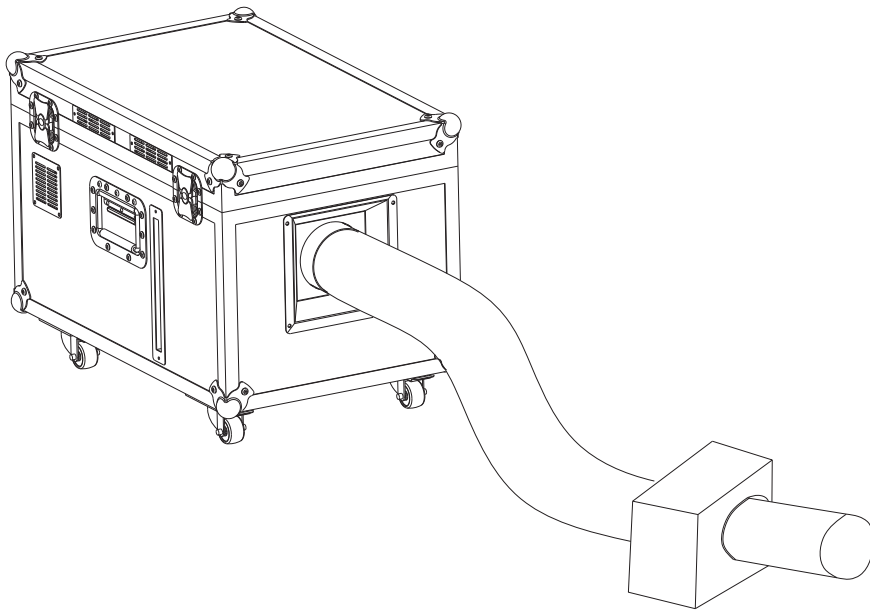

CHAUVET

TABLE OF CONTENTS

1. Before You Begin	1
What Is Included	1
Unpacking Instructions	1
Text Conventions	1
Symbols	1
Disclaimer	1
Product at a Glance	2
Safety Notes	2
2. Introduction	3
Product Overview	3
Product Dimensions	4
3. Setup	5
AC Power	5
Resetting the Breaker	5
4. Operation	6
Control Priority	6
DMX Linking	7
Starting Address	7
5. Maintenance and Storage	8
Hazer Maintenance	8
Storage	8
6. Technical Specifications	9
Returns	10
Contact Us	11

1. BEFORE YOU BEGIN

What Is Included

- Cumulus
- Overflow Tubing
- Hose and Square Holder
- Power Cord
- Warranty Card
- Quick Reference Guide

Unpacking Instructions

Carefully unpack the product immediately and check the container to make sure all the parts are in the package and are in good condition.

Claims





If the box or the contents (the product and included accessories) appear damaged from shipping, or show signs of mishandling, notify the carrier immediately, not Chauvet. Failure to report damage to the carrier immediately may invalidate your claim. In addition, keep the box and contents for inspection.

For other issues, such as missing components or parts, damage not related to shipping, or concealed damage, file a claim with Chauvet within 7 days of delivery.

Text Conventions

CONVENTION	MEANING
1–512	A range of values
50/60	A set of values of which only one can be chosen
Settings	A menu option not to be modified
<ENTER>	A key to be pressed on the product's control panel
ON	A value to be entered or selected

Symbols

SYMBOL	MEANING
	Electrical warning. Not following these instructions may cause electrical damage to the product, accessories, or the user.
	Critical installation, configuration, or operation information. Not following these instructions may make the product not work, cause damage to the product, or cause harm to the operator.
	Important installation or configuration information. The product may not function correctly if this information is not used.
	Useful information.

Disclaimer

Chauvet believes that the information contained in this manual is accurate in all respects. However, Chauvet assumes no responsibility and specifically disclaims any and all liability to any party for any loss, damage or disruption caused by any errors or omissions in this document, whether such errors or omissions result from negligence, accident or any other cause. Chauvet reserves the right to revise the content of this document without any obligation to notify any person or company of such revision, however, Chauvet has no obligation to make, and does not commit to make, any such revisions. Download the latest version from www.chauvetdj.com.

The works of authorship contained in this manual, including, but not limited to, all design, text and images are owned by Chauvet.

© Copyright 2018 Chauvet & Sons, LLC. All rights reserved.

Electronically published by Chauvet in the United States of America.

CHAUVET, the Chauvet logo, and Cumulus are registered trademarks or trademarks of Chauvet & Sons LLC (d/b/a Chauvet and Chauvet Lighting) in the United States and other countries. Other company and product names and logos referred to herein may be trademarks of their respective companies.

Product at a Glance

Use on Dimmer	⊘	Auto Programs	⊘
Outdoor Use	⊘	Auto-ranging Power Supply	⊘
Sound-Active	⊘	Breaker	✓
DMX	✓	User-Serviceable	⊘
Master/Slave	⊘		

Safety Notes



- Not intended for permanent installations.
- Always connect the product to a grounded circuit to avoid the risk of electrocution.
- Make sure the power cord is not crimped or damaged.
- Never disconnect the power cord by pulling or tugging on the cord.
- Make sure there are no flammable materials close to the unit while operating
- Do not touch the output nozzle on this product. It is very hot during operation and it may remain hot for several hours after turning the unit off.
- Do not drink the haze fluid. If you do, call your local emergency service (911 in the US) for help.
- Do not add perfume, alcohol, gasoline, or any other flammables to the haze fluid.
- Depending on the amount of haze generated, all haze machines may set off smoke detectors.
- Do not use for space heating purposes.
- Use only CHAUVET DJ water-based haze fluid.
- Drain the tank before transporting the product.
- Condensation may form on the bottom of the product, creating damp or wet conditions under and around the Cumulus. Use caution! Surfaces around the product may become slippery.



- Always make sure that the voltage of the outlet to which you are connecting the product is within the range stated in the decal or rear panel of the product.
- This product is for indoor use only! To prevent risk of fire or shock, do not expose this product to rain or moisture.
- Always install this product in a location with adequate ventilation, at least 20 in (50 cm) from adjacent surfaces.
- Be sure that no ventilation slots on the unit's housing are blocked.
- Never connect this product to a dimmer or rheostat.
- Never carry the product from the power cord or any moving part. Always use the hanging/mounting bracket.
- The maximum ambient temperature (Ta) is 104 °F (40 °C). Do not operate this product at higher temperatures.
- In the event of a serious operating problem, stop using the product immediately.
- Never try to repair this product. Repairs carried out by unskilled people can lead to damage or malfunction. Please contact the nearest authorized technical assistance center.
- To eliminate unnecessary wear and improve its lifespan, during periods of non-use completely disconnect the product from power via breaker or by unplugging it.



Keep this User Manual for future use. If you sell the product, be sure that the purchaser receives this document.

2. INTRODUCTION

Product Overview

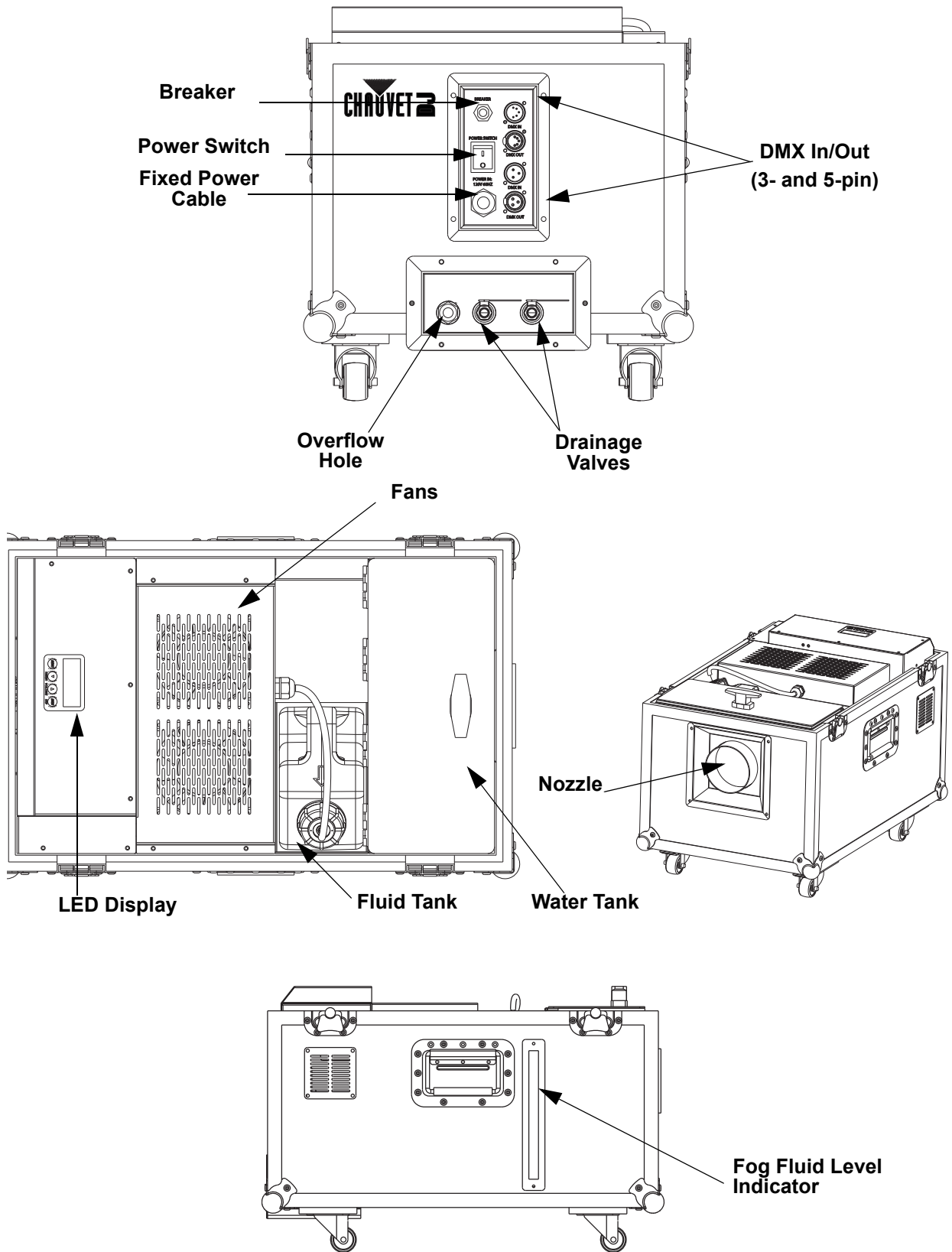

Product Dimensions

16 in
406 mm

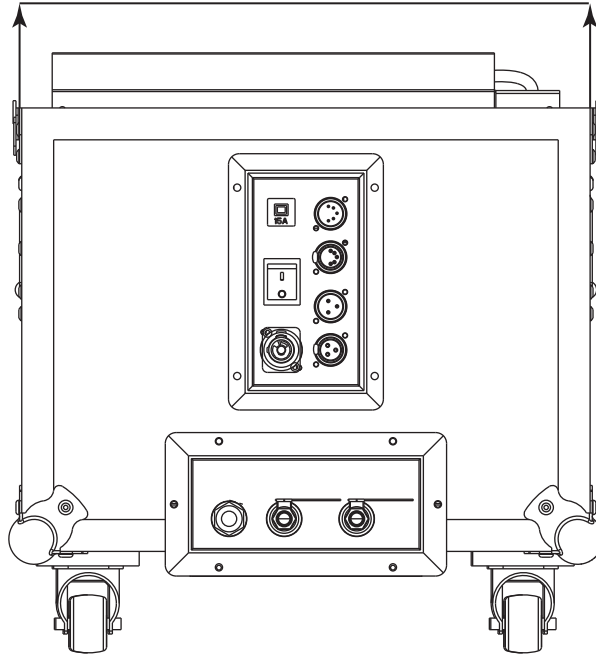

25 in
635 mm

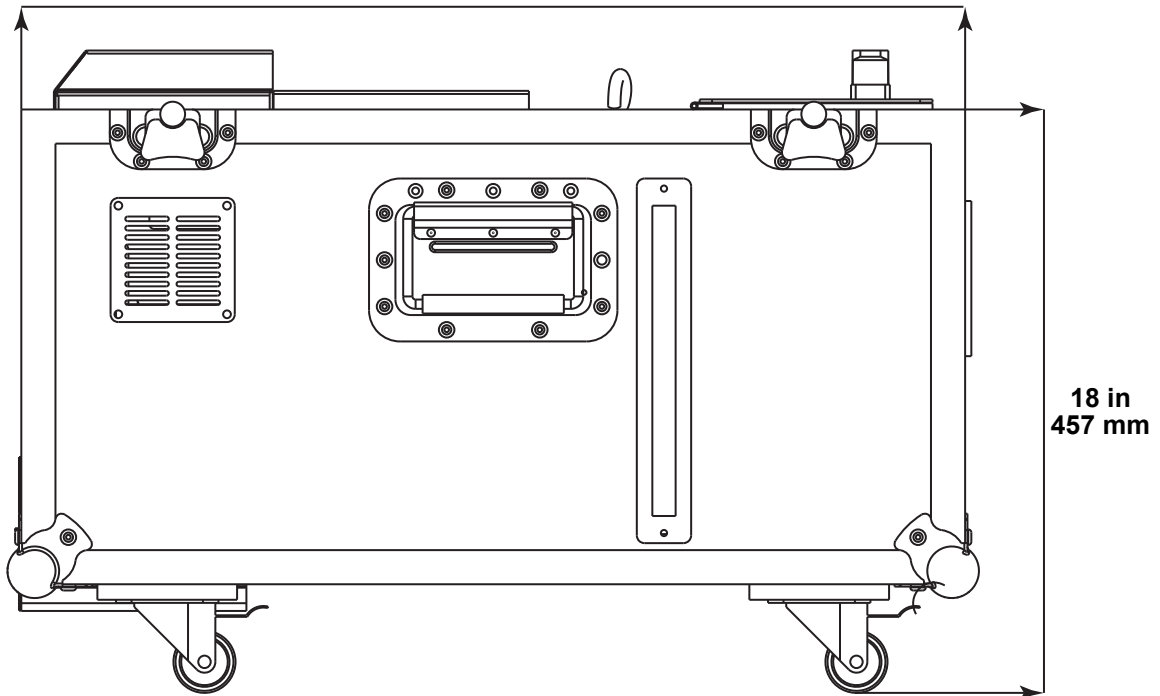

18 in
457 mm

3. SETUP

AC Power

The Cumulus has a fixed voltage power supply and it can work with an input voltage of either 120 VAC, 60 Hz or 230 VAC, 50 Hz, depending on the specific model.



To eliminate wear and improve its lifespan, during periods of non-use completely disconnect the product from power via breaker or by unplugging it.



While operating the Cumulus, make sure there is adequate haze fluid in the machine to prevent pump and heater damage. When the haze fluid level becomes low, simply add more haze fluid to continue using the Cumulus.



This product may NOT be tilted. This product should be level when on a surface.

Resetting the Breaker

This product is equipped with a resettable circuit breaker. If the breaker trips, all sections of this product will lose power.

1. Remove the power cord from mains power.
2. Allow unit to cool for 15 minutes.
3. After 15 minutes, you may attempt to reset the breaker by pressing the button with your finger.
4. Plug the product's power cord into the power outlet and continue using as recommended.

4. OPERATION

Control Priority

The Cumulus operates according to the following priority control levels:

Control Panel Operation

To access the control panel functions, use the four buttons located underneath the display, and the two manual control knobs located to the right of the display. Please refer to the Product Overview to see the button and knob locations on the control panel.

Control Panel Description

BUTTON/KNOB	FUNCTION
<MENU>	Exits from the current menu or function
<UP/TIMER>	UP navigates upwards through the menu list and increases the numeric value when in a function. TIMER starts the timer controlled operation
<DOWN/ VOLUME>	DOWN navigates downwards through the menu list and decreases the numeric value when in a function. VOLUME triggers the pump to modify the output volume
<ENTER/ STOP>	ENTER enables the currently displayed menu or sets the currently selected value into the selected function. STOP turns the fog output off.

Programming

Refer to the Menu Map to understand the menu options. The menu map shows the main level and a variable number of programming levels for each option.

- To go to the desired main level, press <**FUNCTION**> repeatedly until the option shows on the display. This will take you to the first programming level for that option.
- To select an option or value within the current programming level, press <**UP**> or <**DOWN**> until the option shows on the display. If there is another programming level, you will see that first option, or you will see the selected value.
- Press <**FUNCTION**> repeatedly to exit to the previous main level.

Operation

1. Place the machine on a level surface. Plug the power cord into the wall.
2. Remove the top lid.
3. Fill the water tank with distilled water to the maximum fill line located on the inside of the tank. The container can hold up to 2 gal or (7.6 l).
4. Fill the fluid tank with CHAUVET haze or fog fluid to the maximum fill line located on the outside of the tank. The container can hold up to 1 gal (3.8 l).
5. Turn the product on using the power switch on the back panel. Make sure the fans are operating properly.
6. Using the control panel, set the product to the desired operating mode.



- **Due to water evaporation, you may need to refill the Cumulus with water to continue triggering the machine.**
- **The Cumulus is fitted with a safety shutoff feature, which prevents the unit's heaters from turning on when the water level is too low. If this safety shutoff feature has been engaged, simply add more water to continue using the Cumulus.**



The Cumulus can operate with the top lid on or off.

Menu Map

MODE	PROGRAMMING LEVELS	DESCRIPTION
Interval Set	5–200	Sets the interval between fog output
Duration Set	5–200	Sets the duration of the fog output
Timer Out	1-100%	Sets the output volume in timer mode
Volume Out	1–100%	Fog volume 1–100%
Fan Speed	1–100%	Fan Speed (slow to fast)
Fluid Sensor	ON/OFF	Turns the fluid sensor ON or OFF
DMX 512	1–512	Selects the DMX starting address
Direct Timer	ON/OFF	Enables/disables the timer



If the product is turned off while in timer mode, the product will still be in timer mode when the product is turned back on.



Ensure both valves are closed before filling the product with fluids.



Condensation may form on the bottom of the product, creating damp or wet conditions under and around the Cumulus. Use caution! Surfaces around the product may become slippery.

DMX Linking

The Cumulus can work with a DMX controller. Instructions for connecting and configuring this product for DMX operation are in the User Manual. If you are not familiar with DMX, download the DMX Primer from www.chauvetdj.com.

Starting Address

To ensure full access to all channels available in DMX mode, the highest recommended DMX address is 511.



Allow the Cumulus three minutes to heat up before continuing.

DMX Values

2-CH

CHANNEL	FUNCTION	VALUE	PERCENT/SETTING
1	Fan Speed	000 ⇔ 010	No function
		011 ⇔ 512	1–100%
2	Fog Output	000 ⇔ 010	No function
		011 ⇔ 512	1–100%

5. MAINTENANCE AND STORAGE

Hazer Maintenance

Do not allow the fogger to become clogged. After every 40 hours of continuous operation, use CHAUVET Fog Cleaner Quart (FCQ) through the system to prevent the accumulation of particulate matter in the heating element.

The recommended cleaning procedure is as follows.

1. Unplug the product from power.
2. Empty all fog fluid from the machine.
3. Add cleaning solution to the tank.
4. Connect the product to power and allow it to warm up.
5. Run the unit in a well-ventilated area until the tank is almost empty. Do not allow the pump to run dry.
6. Refill with fog fluid to continue using the fogger. Run the machine briefly to clear any remaining cleaning solution from the pump and heater.



Never operate the machine without fluid.



Fog Cleaner Quart (FCQ) was specifically developed by Chauvet to clean your Cumulus. Make sure you use FCQ regularly, no longer than 90 days between cleanings, to increase the life of your product.



Test-run your Cumulus on a monthly basis to achieve the best performance.

Storage

Before storing the fogger, run FCQ through the system as described in the cleaning procedure above; however, only follow steps 1 through 5. **Do not refill the tank with fog fluid if storing the fogger.** Cleaning the system prior to storage will help prevent any particles from condensing inside the pump or heater while not in use.

6. TECHNICAL SPECIFICATIONS

Dimensions and Weight

LENGTH	WIDTH	HEIGHT	WEIGHT
25 in (635 mm)	16 in (406 mm)	18 in (457 mm)	58.8 lb (26.7 kg)

Note: Dimensions in inches rounded to the nearest decimal digit.

Power

POWER SUPPLY TYPE	RANGE	VOLTAGE SELECTION
Fixed	120 VAC, 60 Hz, or 230 VAC, 50 Hz	Fixed
PARAMETER	120 V, 60 HZ	230 V, 50 HZ
Consumption	970 W	970 W
Operating Current	8 A	4 A
Breaker	F 8 A, 250 V	F 8 A, 250 V
POWER I/O	U.S./WORLDWIDE	UK/EUROPE
Power input connector	IEC	IEC
Power Cord plug	Edison (U.S.)	Local Plug

Operation

HEAT-UP TIME	FLUID TANK CAPACITY	WATER TANK CAPACITY
3 min	1 gal (3.8 l)	2 gal (7.6 l)
3 min	Consumption: 80ml/min	Consumption: 930 ml/min

Thermal

MAXIMUM EXTERNAL TEMPERATURE	COOLING SYSTEM
104 °F (40 °C)	Convection

DMX

I/O CONNECTOR	CHANNEL RANGE
3-pin or 5-pin XLR	2

Ordering

PRODUCT NAME	ITEM CODE	UPC NUMBER
Cumulus (120 V)	05071416	781462217648
Cumulus (230 V)	05071420	781462217686

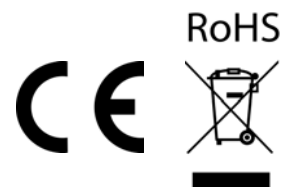

RETURNS

In case you need to get support or return a product:

- If you are located in the U.S., contact Chauvet World Headquarters.
- If you are located in the UK or Ireland, contact Chauvet Europe Ltd.
- If you are located in Mexico, contact Chauvet Mexico.
- If you are located in Benelux, contact Chauvet Europe BVBA.
- If you are located in any other country, DO NOT contact Chauvet. Instead, contact your local distributor. See www.chauvetdj.com for distributors outside the U.S., UK, Ireland, Mexico, or Benelux.



If you are located outside the U.S., UK, Ireland, Mexico, or Benelux, contact your distributor of record and follow their instructions on how to return Chauvet products to them. Visit our website www.chauvetdj.com for contact details.

Call the corresponding Chauvet Technical Support office and request a Return Merchandise Authorization (RMA) number before shipping the product. Be prepared to provide the model number, serial number, and a brief description of the cause for the return.

Send the merchandise prepaid, in its original box, and with its original packing and accessories. Chauvet will not issue call tags.

Clearly label the package with the RMA number. Chauvet will refuse any product returned without an RMA number.



Write the RMA number on a properly affixed label. DO NOT write the RMA number directly on the box.

Before sending the product, clearly write the following information on a piece of paper and place it inside the box:

- Your name
- Your address
- Your phone number
- RMA number
- A brief description of the problem

Be sure to pack the product properly. Any shipping damage resulting from inadequate packaging will be your responsibility. FedEx packing or double-boxing are recommended.



Chauvet reserves the right to use its own discretion to repair or replace returned product(s).

CONTACT US

World Headquarters	
General Information	Technical Support
Address: 5200 NW 108th Ave. Sunrise, FL 33351 Voice: (954) 577-4455 Fax: (954) 929-5560 Toll Free: (800) 762-1084	Voice: (844) 393-7575 Fax: (954) 756-8015 Email: chauvetcs@chauvetlighting.com
Website	
www.chauvetdj.com	
EUROPE	
General Information	Technical Support
Address: Stokstraat 18 9770 Kruishoutem Belgium Voice: +32 9 388 93 97	Email: eutech@chauvetlighting.eu
Website	
www.chauvetdj.eu	
General Information	
General Information	Technical Support
Address: Unit 1C Brookhill Road Industrial Estate Pinxton, Nottingham, UK NG16 6NT Voice: +44 (0) 1773 511115 Fax: +44 (0) 1773 511110	Email: uktech@chauvetlighting.com
Website	
www.chauvetdj.eu	
MEXICO	
General Information	Technical Support
Address: Av. de las Partidas, 34-3B, Zona Industrial Lerma (Entrance by Calle 2) Lerma, Edo. de Mexico C.P. 52000 Voice: +52 (728) 690-2010	Email: servicio@chauvet.com.mx
Website	
www.chauvetdj.mx	

Visit the applicable website above to verify our contact details and instructions to request support. Outside the U.S., United Kingdom, Ireland, Mexico or Benelux, contact the dealer of record.